

REVISIONS			
NO	DESCRIPTION	APPROVED	DATE

Impedance.....50Ω
 Frequency range.....DC ~ 6GHz
 V.S.W.R.....N/A
 Dielectric withstanding
 - Voltage(at sea level).....500Vrms.50Hz
 - Working voltage(at sea level).....≤170Vrms.50Hz
 Insulation resistance.....≥10³ MΩ
 Center contact resistance.....≤5.0MΩ
 Out contact resistance.....≥2.5MΩ
 Temperature range.....-55℃ ~ +155℃
 Temperature shock.....MIL-STD202,Method107,ConditionF
 Moisture resistance.....MIL-STD202,Method106
 Corrosion.....Saltspray Test acc.to MIL-STD-202,
 Method101,ConditionB
 Vibration.....MIL-STD202,Method204,ConditionC
 Engagementforce.....≤15N/3.4lbs.
 Disengagementforce.....6N-15N/1.4lbs.-3.4lbs.
 Contact captivation.....≥10N/2.3lbs.
 Durability(Matings).....≥500

Connector parts	Material	Plating
Bodys	Brass	Gold
Center contact	Beryllium-copper	Gold
Insulator	PTFE	White

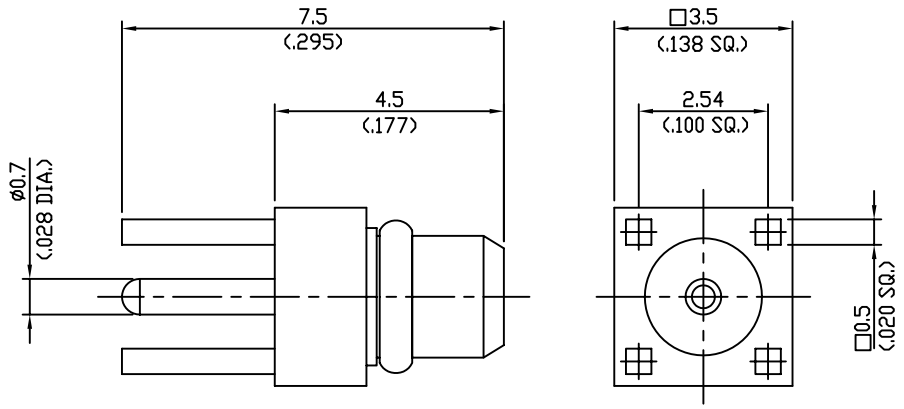

Mounting hole

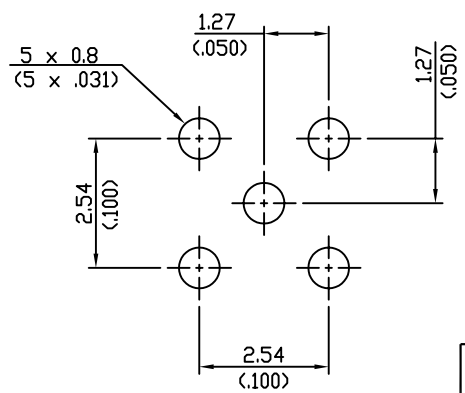

TOL.UNLESS NOTED
 X = ±0.1
 X.X = ±0.05
 X.XX = ±0.01

DATE	
DRAWN BY	
DESIGNED BY	
CHECKED BY	
APPD.BY	
SCALE 1 : 1	UNIT mm

 www.rfacsolutions.com

TITLE
 MMCX STRAIGHT
 PCB PLUG

DRAWING NO
 R310-021-000

SHEET 1 OF 1